

1 Atornillar guía superior e inferior a marco y contramarco previa introducción de los frenos de guía.

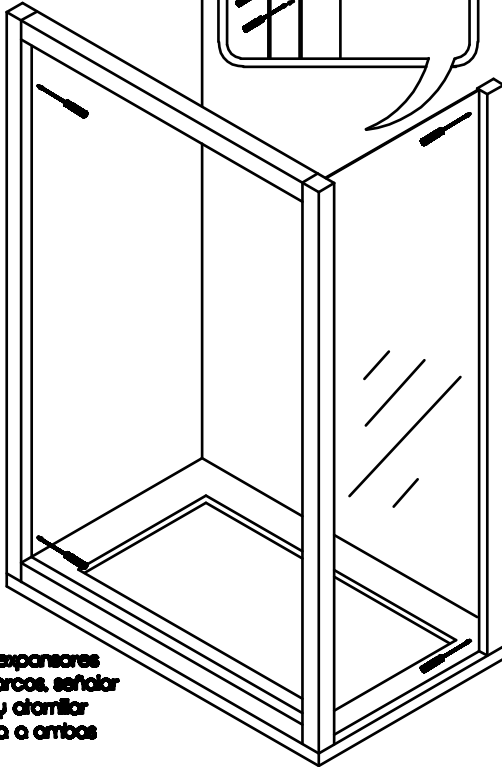

2 Colocar espansores en los marcos, señalar tornillos y atornillar mampara a ambas paredes.

3 Rellenar con silicona el alojamiento del marco para el fijo, e introducir vidrio fijo.

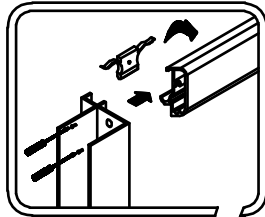
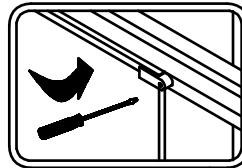
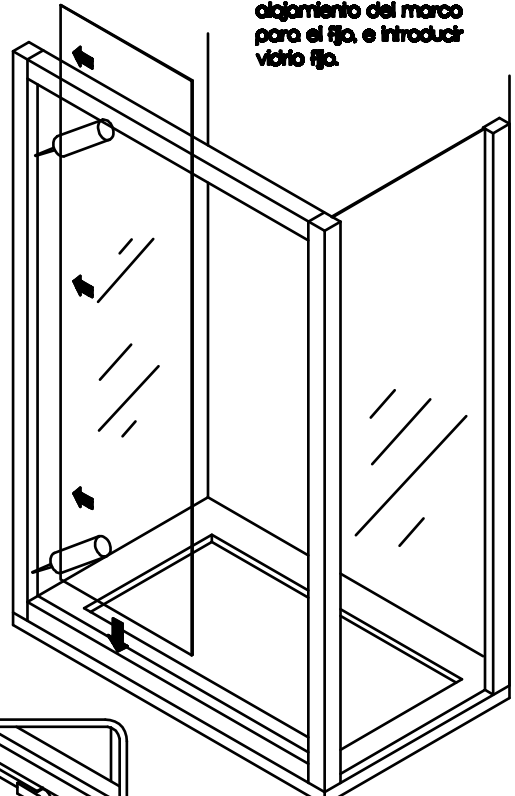

4 Señalar, taladrar y atornillar topes cogido fijo a guías.

5 Colocar, gomas de cruce e iman de la hoja, posteriormente colocar rodamientos en la parte superior e inferior del vidrio y colgar la hoja.

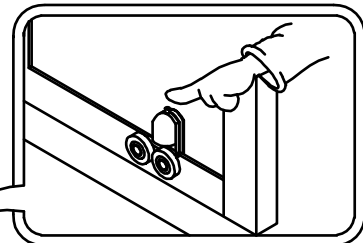
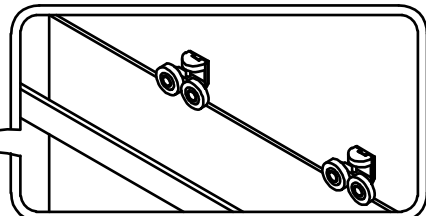
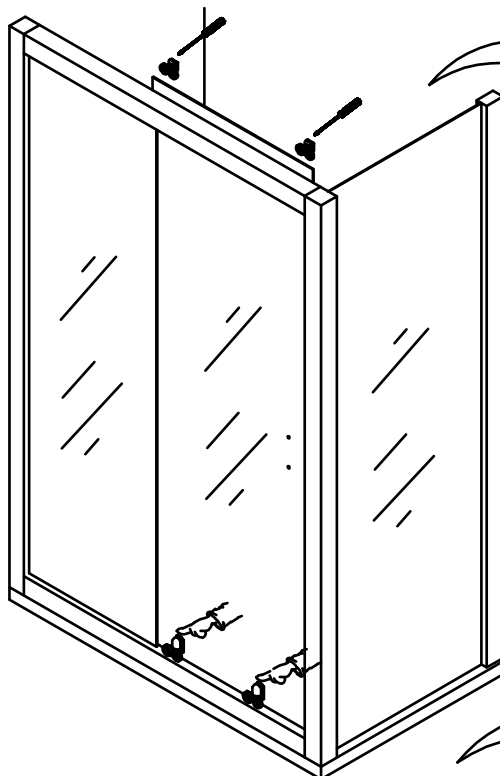
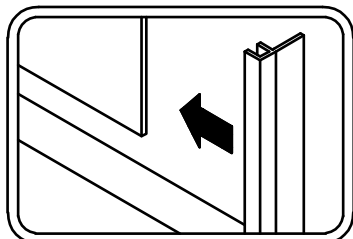
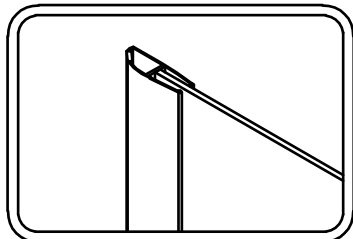

6

Graduamos los hojas mediante los tornillos de regulación de los rodamientos y colocamos los tiradores.

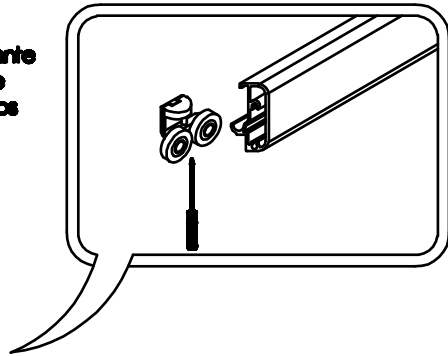
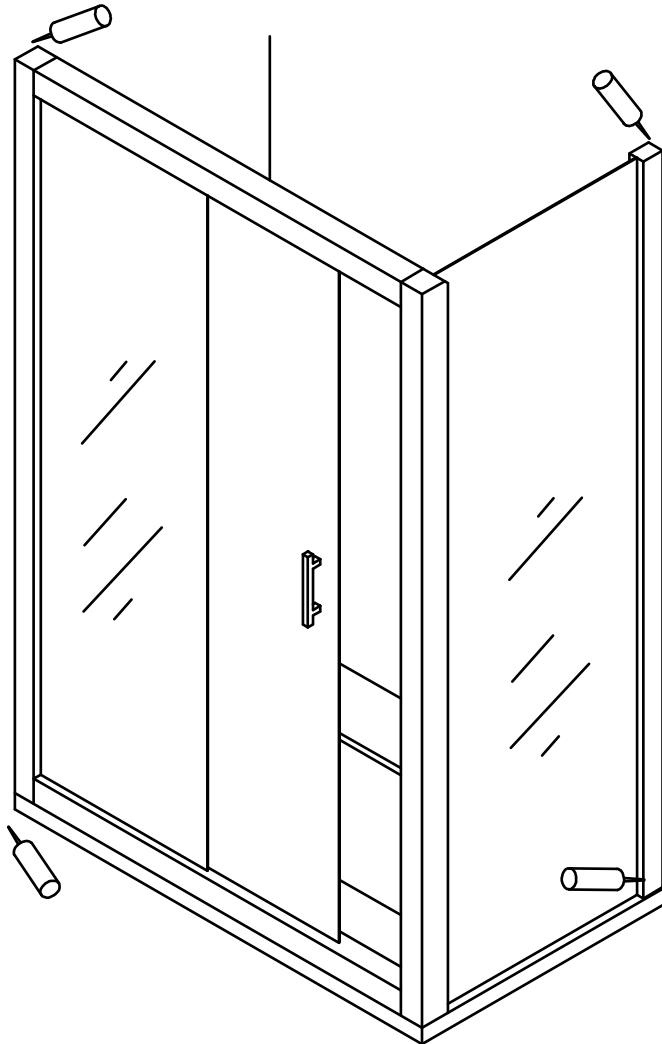

7

Sellado del contorno de la mampara y colocación de topes superiores.

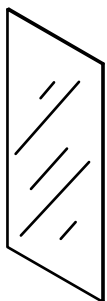
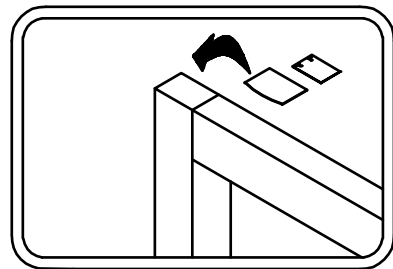

1+1 (p)
vidrio hoja fija

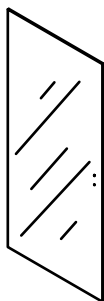

1x
vidrio hoja
corredera

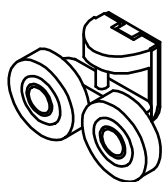

2x
rodamientos de
acero inoxidable

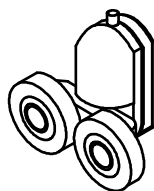

2x
rodamientos

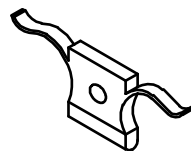

2x
freno

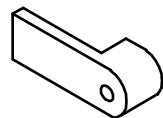

2x
cogidos fijo

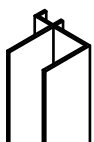

1x
contramarco

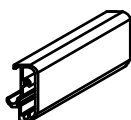

2x
guía superior e inferior



1x
marco lateral

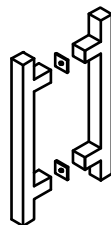

1x
tirador

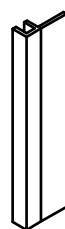

2x
gomas cruce



1x
Iron cierre

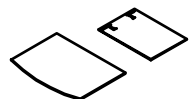

2x
juegos
topes superiores