

1 Atornillar guía superior e inferior a marco y contramarco previa introducción de los frenos de guía.

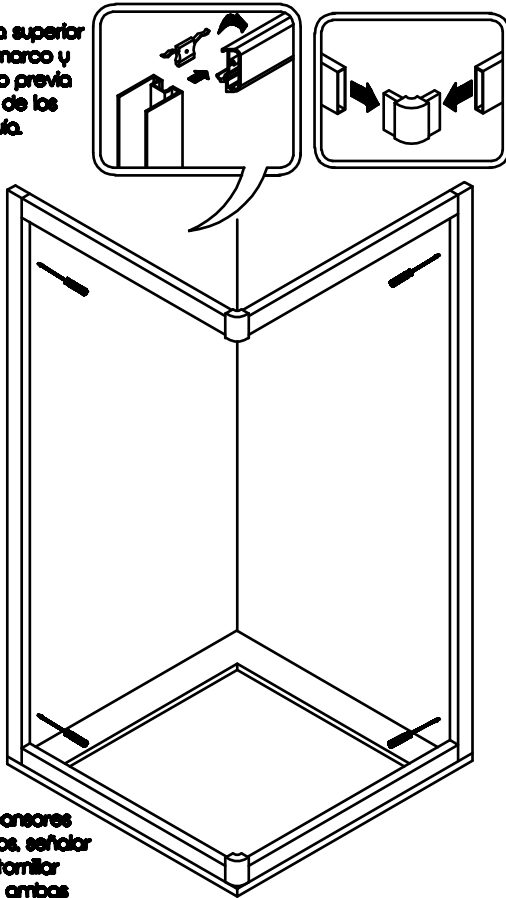

2 Colocar expansores en los marcos, señalar taladros y atornillar mampara a ambas paredes.

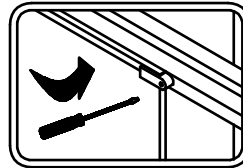

3 Rellenar con silicona el alojamiento del marco para el fijo, e introducir vidrio fijo.

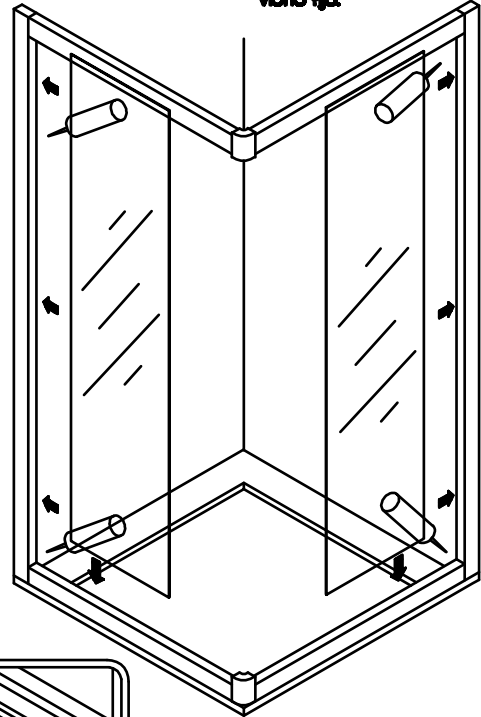

4 Señalar, taladrar y atornillar topes cogida fijo a guías.

5 Colocar, gomas de cruce e iman de la hoja, posteriormente colocar rodamientos en la parte superior e inferior del vidrio y colgar la hoja.

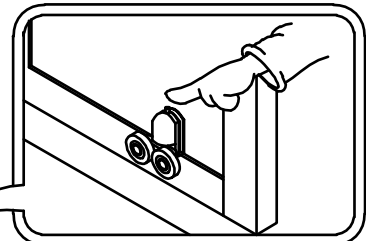
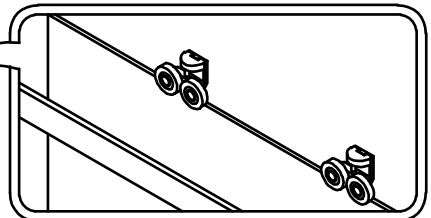
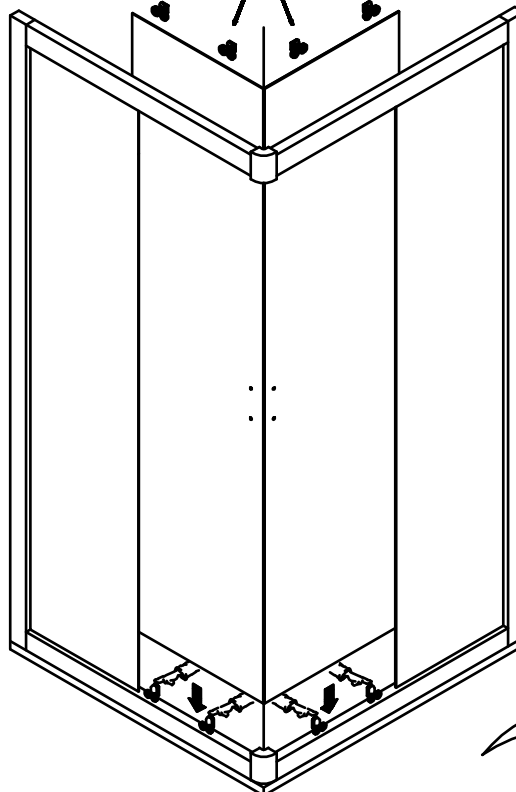
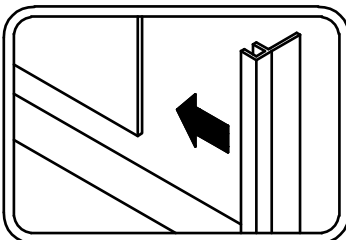
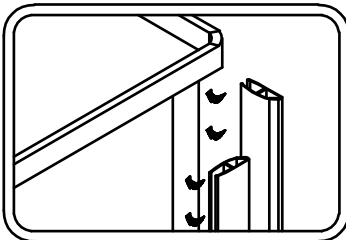

6

Graduamos los hojas mediante los tornillos de regulación de los rodamientos y colocamos los tiradores.

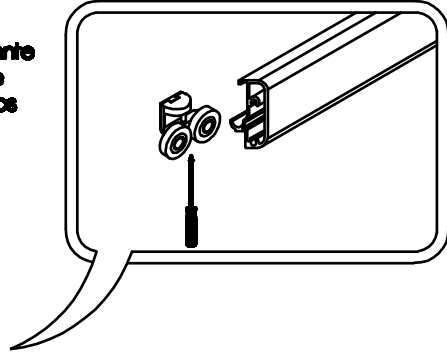
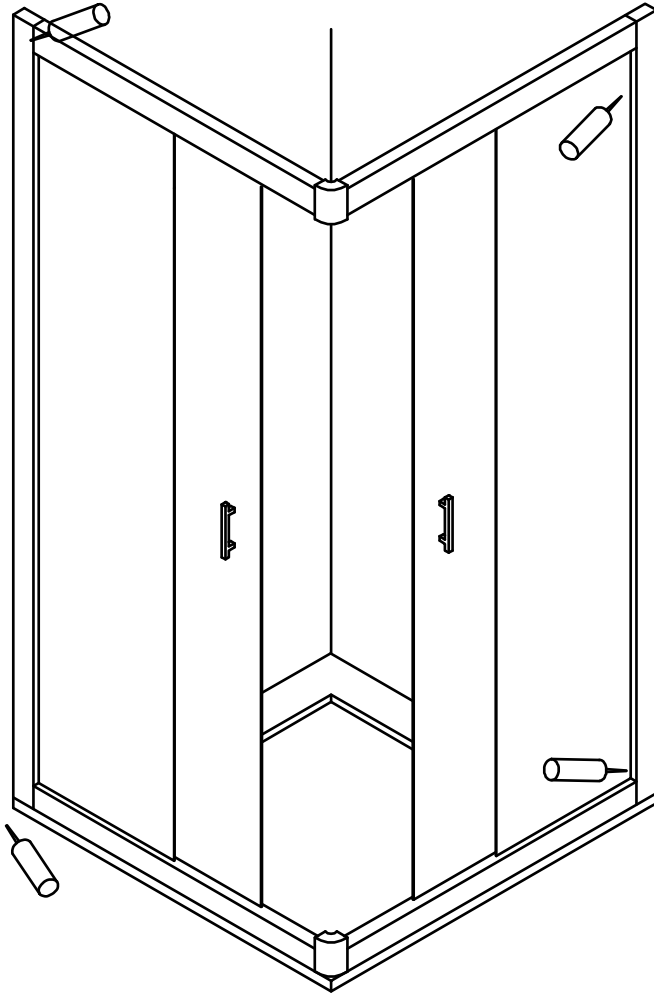

7

Sellado del contorno de la mampara y colocación de topes superiores.

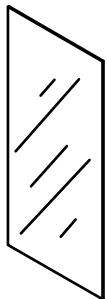
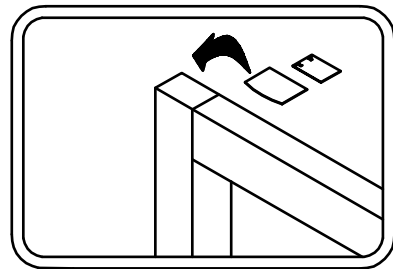

2 x vidrio hoja fija

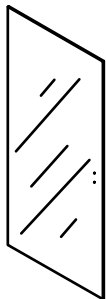

2 x vidrio hoja corredera

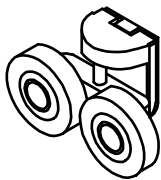

4 x rodamientos de acero inoxidable

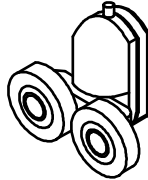

4 x rodamientos

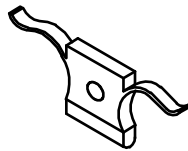

6 x freno

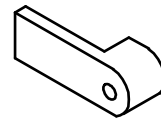

4 x cogidos fijo

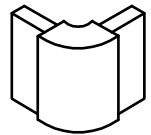

2 x escuadra

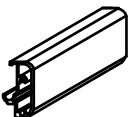

4 x guía superior e inferior

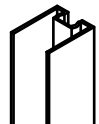

2 x marco lateral

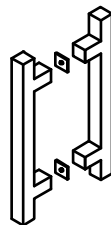

2 x tirador



4 x gomas cruce

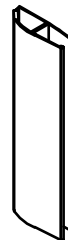

2 x tron cierre

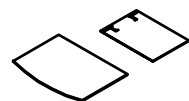

2 x juegos topes superiores